

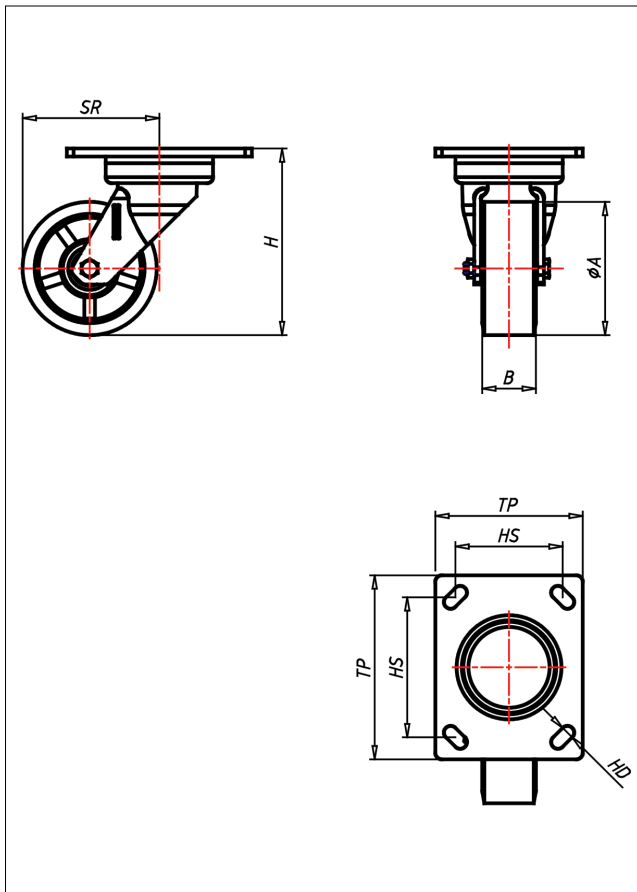

# GT-ZK/SUB/LZK

## Lenkrolle

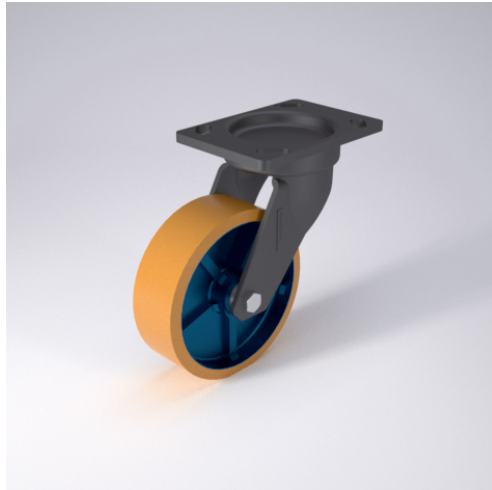

### GT-SU



LENKROLLE	RADFESTSTELLER	BOCKROLLE																				
 <ul style="list-style-type: none"> <li>geräuscharmer Lauf</li> <li>geringer Rollwiderstand</li> <li>abrieb- und reifest</li> <li>hohe Stofestigkeit</li> <li>sehr bestndig gegen viele aggressive Medien</li> </ul> <p>Guss-Polyurethan Felge Gusseisen lackiert → Seite 247</p> 	 <p>Schwerlastlenkgehuse ohne Mittelbolzen mit gehrtetem Drehkranz und gehrteten Stahlkugeln, geschmiedet und getempert</p> <p>→ Seite 42</p>	 <p>AUSWAHLHILFE:</p> <table border="0"> <tr> <td>leicht lenkend</td> <td>-</td> <td>+</td> <td>++</td> </tr> <tr> <td>verschleißarm</td> <td>x</td> <td></td> <td></td> </tr> <tr> <td>stofest</td> <td></td> <td>x</td> <td></td> </tr> <tr> <td>bodenschonend</td> <td></td> <td></td> <td>x</td> </tr> <tr> <td>witterungsbestndig</td> <td>x</td> <td></td> <td></td> </tr> </table>	leicht lenkend	-	+	++	verschleißarm	x			stofest		x		bodenschonend			x	witterungsbestndig	x		
leicht lenkend	-	+	++																			
verschleißarm	x																					
stofest		x																				
bodenschonend			x																			
witterungsbestndig	x																					

### Technische Details

<b>ORDERNO (Artikel-nummer)</b>	GT 250 LZK
<b>WDAB (Rad-Ø A x Breite B / mm)</b>	250x50
<b>LC (Tragkraft / kg)</b>	1200
<b>H (Bauhhe H / mm)</b>	300
<b>TP (Plattengre / mm)</b>	150x105
<b>HS (Lochabstand / mm)</b>	105x80
<b>HD (Loch-Ø / mm)</b>	13
<b>SR (Schwenkradius / mm)</b>	188
<b>WB (Radlager)</b>	Kugellager